



CENTROTECNICA
stress to ensure

the **Instant Clamp**

NO SCREWS, SAME LOCKING, MUCH FASTER

Simply a revolutionary way to mount your fixtures

The **Instant Clamp** is a patent pending simple and reliable tool to save time and efforts.

The **Instant Clamp** is an absolutely innovative and revolutionary product aimed at those who carry out vibrational testing activities.

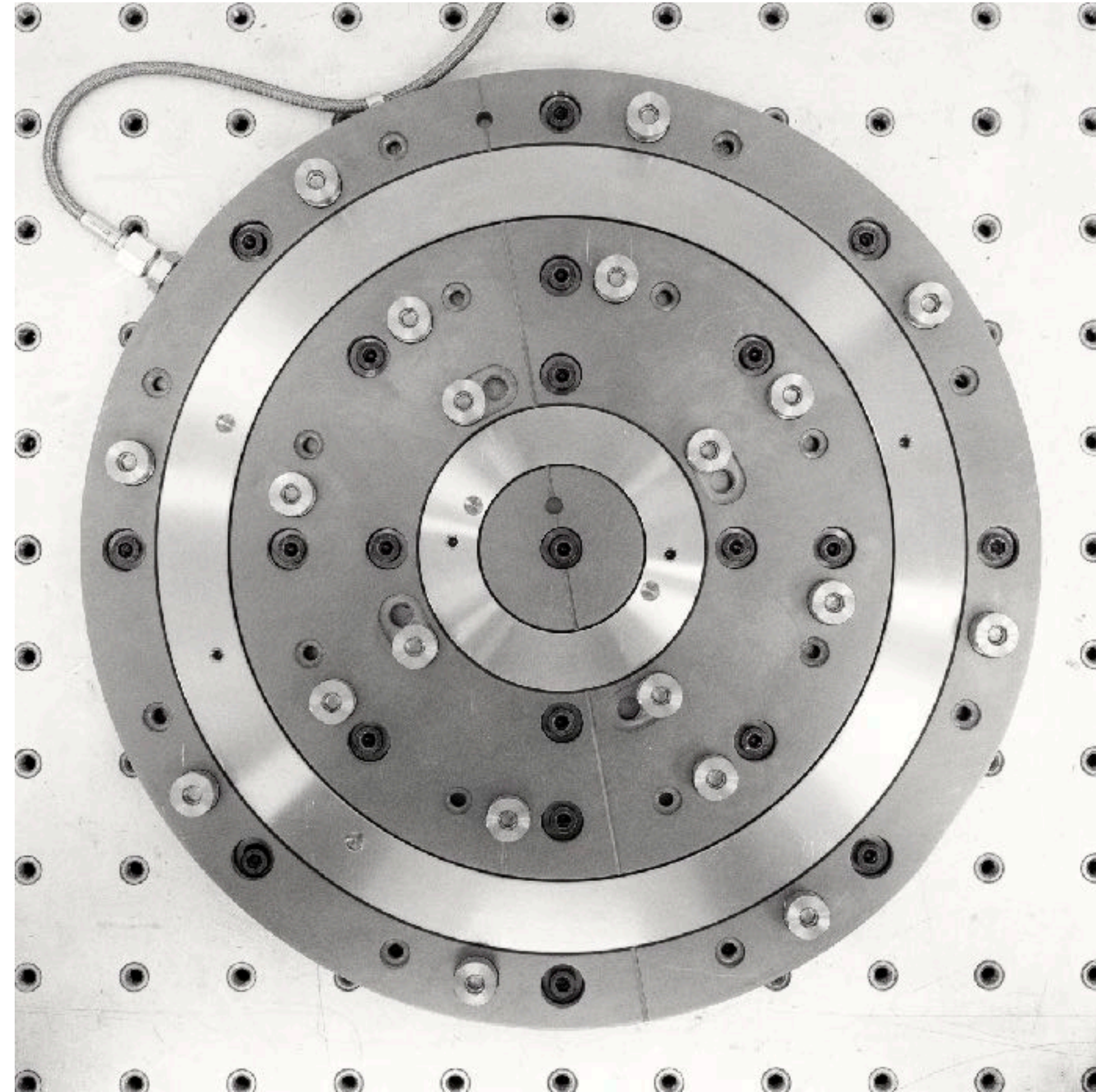

It is the result of 4 years of research by our R&D department and has been extensively tested in our testing house.

NO SCREWS, SAME LOCKING, MUCH FASTER

Great time savings in setting up for the test.

There are **no more screws to tighten**, therefore the manual mounting work is reduced to the positioning of the fixture only.

Operations that up to now have required considerable time in the economy of a test, can be reduced to half a minute.

Time savings that must be multiplied by each vibration axis to be tested.



EASY HARDWARE, EASY SETUP



The hardware required to operate this mechanism is limited to a connection to an air compressor, usually already on place where a shaker is located.

Inside the control panel, a pressure multiplier provides the clamping pressure to the hydraulic fluid.

The **Instant Clamp** is simply separated from the control panel with a quick release. This further simplifies and speeds up work processes and prevents oil leaks when removing the **Instant Clamp** from the climate chamber.

In order to prevent potential hazards, when not under pressure the **Instant Clamp** inhibits the shaker from start.



SIMPLIFIED FIXTURE DESIGN

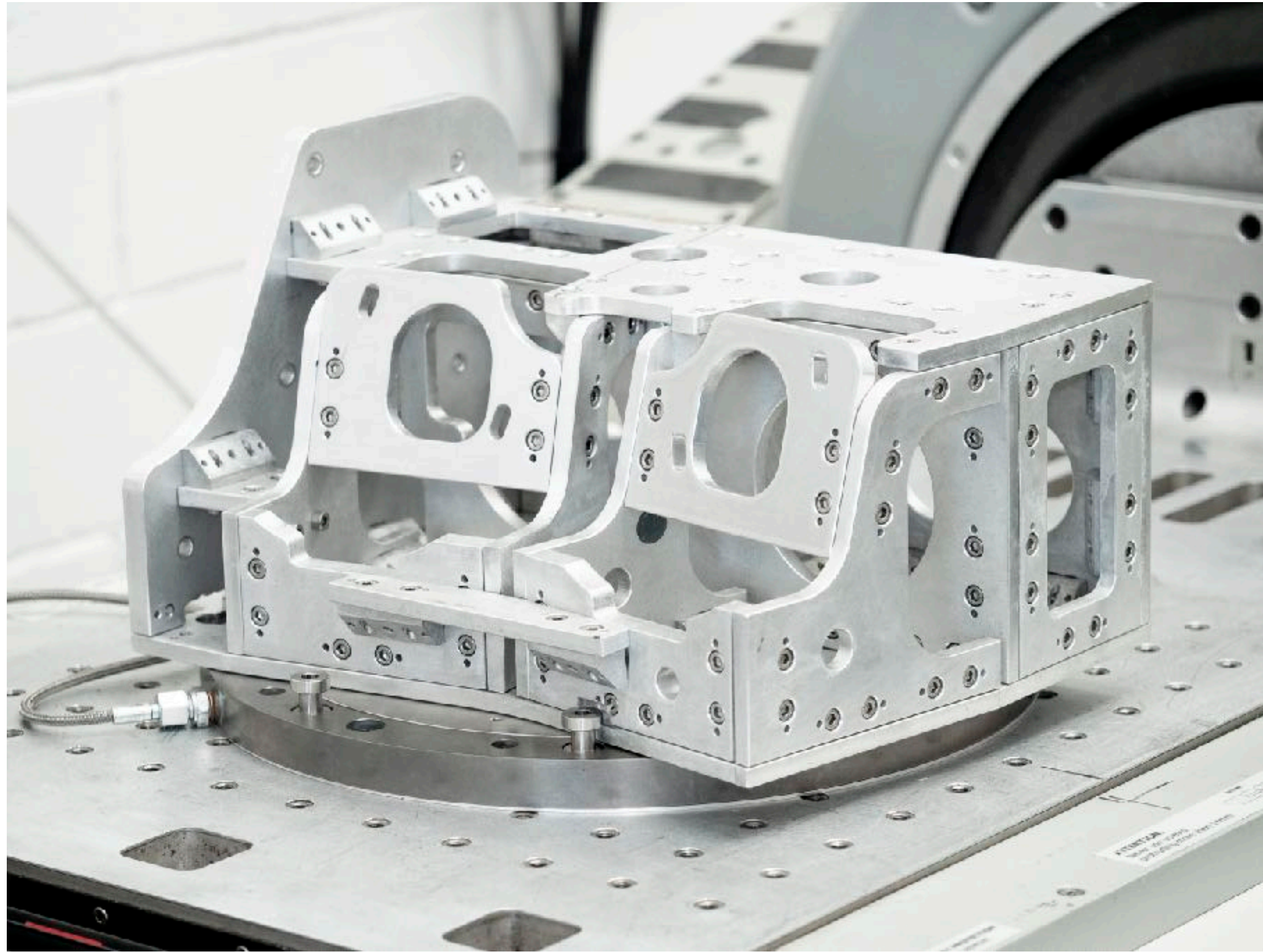

The design of the fixtures is also considerably simplified. Since it is no longer necessary to consider the spaces for human intervention in tightening the screws, a simpler and more compact design can be adopted, with advantages both from an economic point of view and in the fixture efficiency (smaller resonances).

In addition, any fixture, even if not originally arranged, can be modified by our workshop to match the **Instant Clamp**.

CASE STUDY OF AN AUTOMOTIVE FIXTURE FOR 3 TAILLIGHTS:

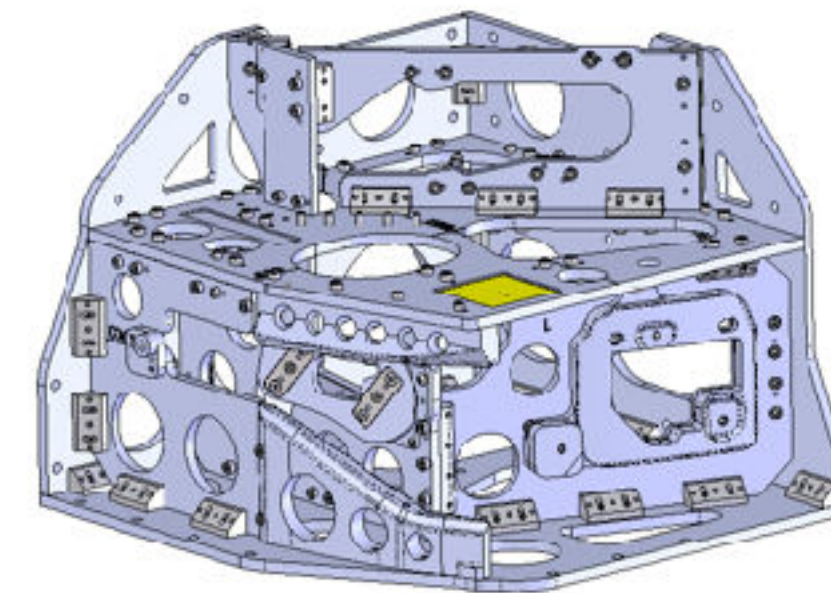

Original fixture design

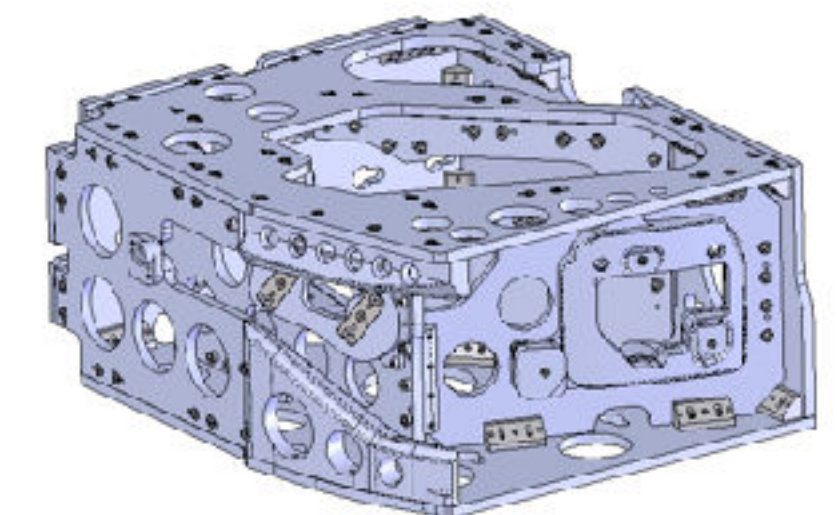

Fixture design for Instant Clamp

DESIGNED TO OFFER A USER FRIENDLY EXPERIENCE

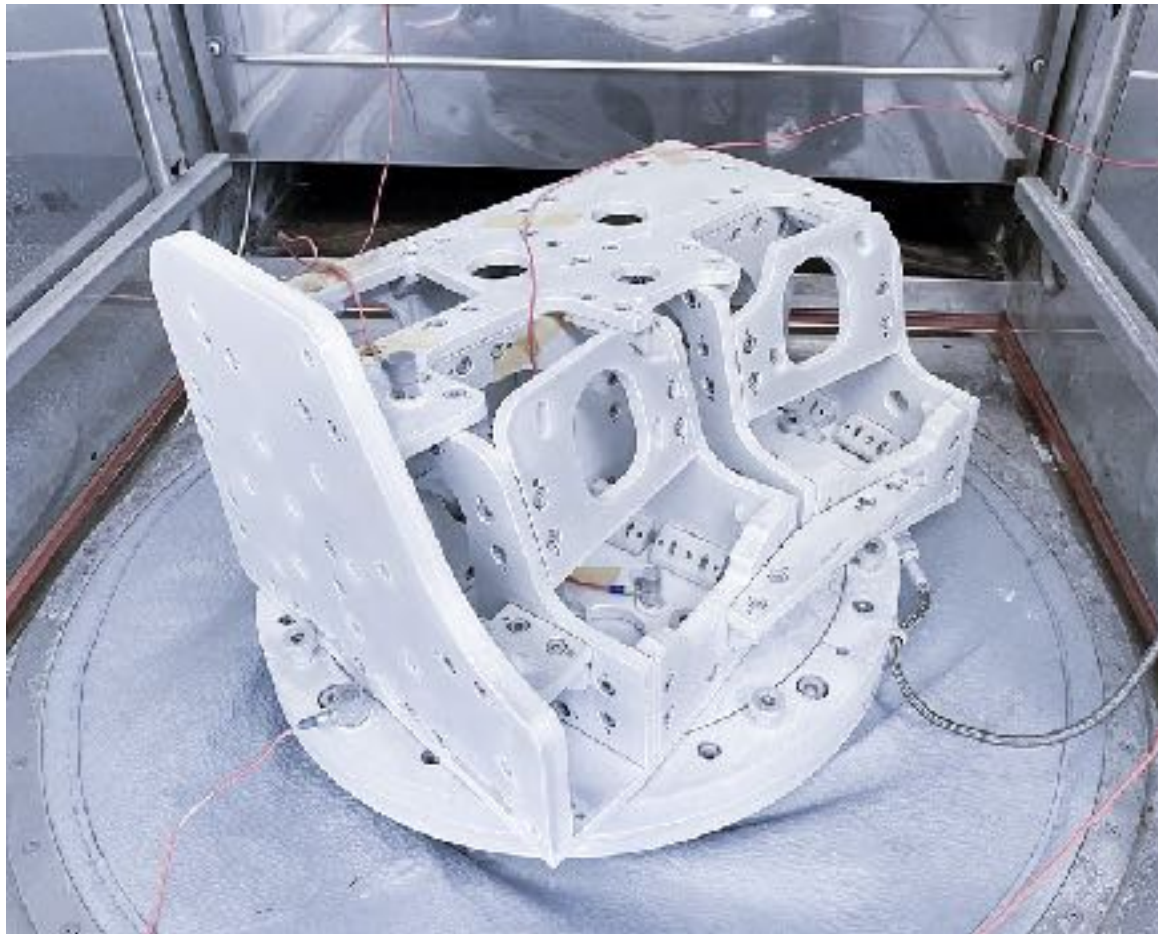

The **Instant Clamp** uses components that allow it to work with a range of temperatures between $-40\text{ }^{\circ}\text{C}$ and $+160\text{ }^{\circ}\text{C}$, therefore they are also suitable for combined tests in climatic chambers, an environment in which fixture mounting is usually hard and complex.

The wedges are accessories designed to facilitate the heavy fixtures manual positioning.

Their function is shown by the video presentation of the **Instant Clamp** (link in the last page).

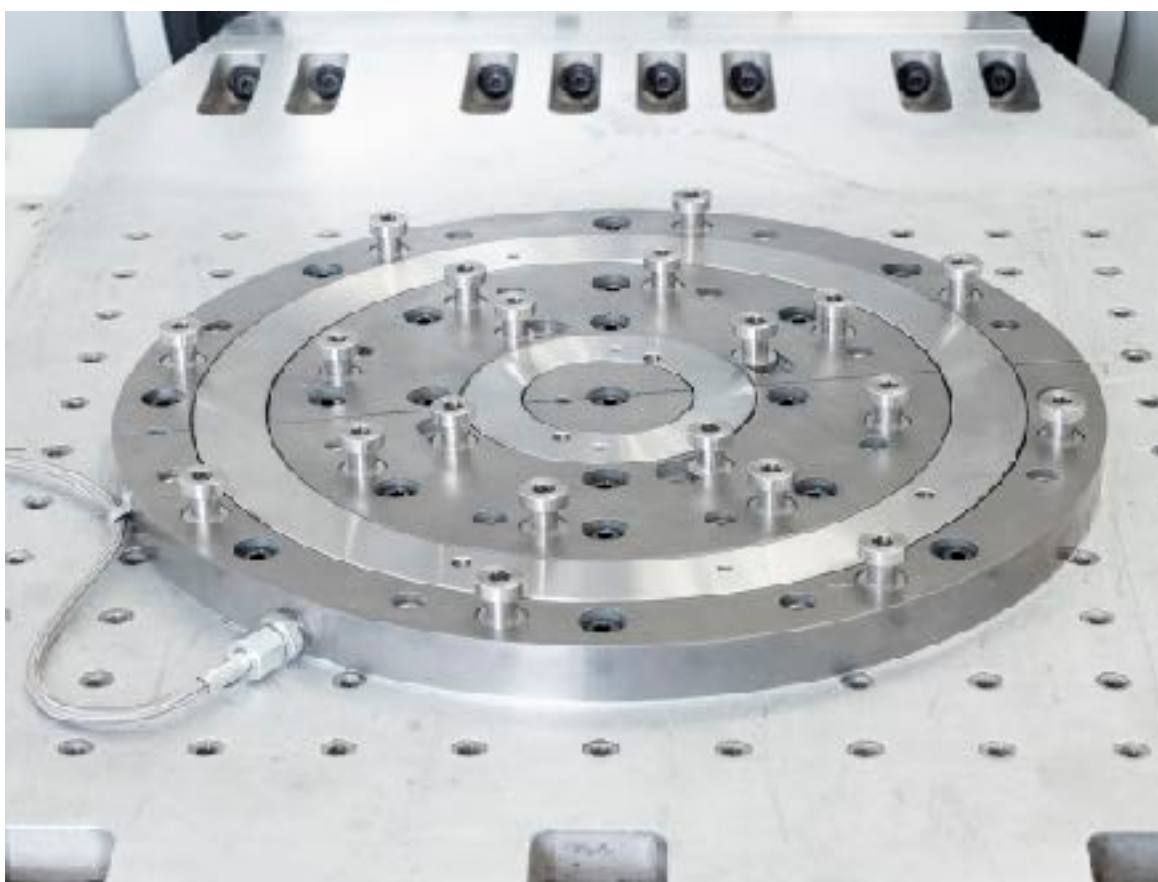

The **tightening is equivalent to the screws** tightened to torque, therefore it's been positively tested both on shaker and slip table, for sine, random and shock tests in a **frequency range up to 2000 Hz**.

The quick release of the whole setup makes it **very safe** and speeds up sample isolation **in the event of a fire when testing the battery**.



STANDARD MODELS CATALOG

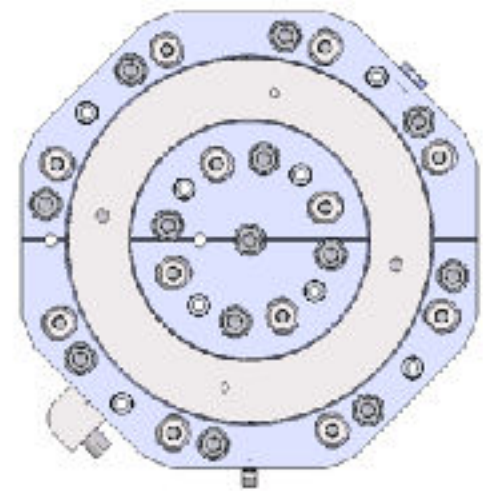

Instant Clamp 290 M	
size	ø 290 mm
weight	6,9 kg
usable frequency range	2000 Hz
temperature range	-40°C ÷ +160°C
interface	metric armature
fixing points	n° 4 on PCD ø 100 mm n° 8 on PCD ø 250 mm

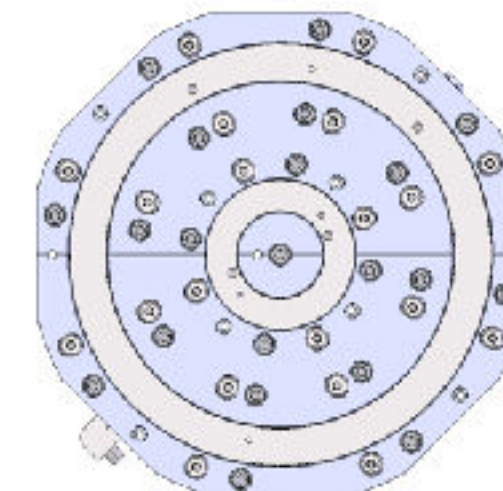

Instant Clamp 440 M	
size	ø 440 mm
weight	14,6 kg
usable frequency range	2000 Hz
temperature range	-40°C ÷ +160°C
interface	metric armature
fixing points	n° 4 on PCD ø 160 mm n° 8 on PCD ø 250 mm n° 8 on PCD ø 400 mm

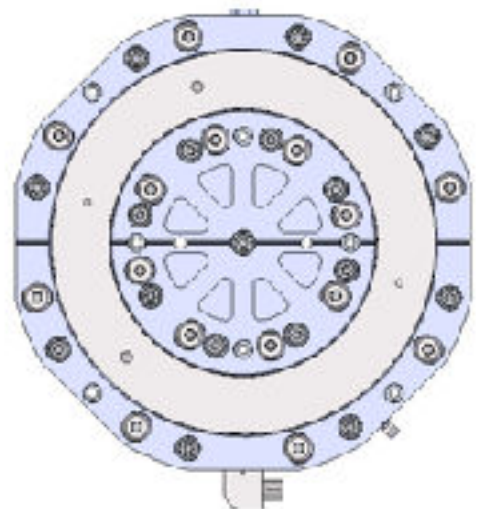

Instant Clamp 335 I	
size	ø 335 mm
weight	9,0 kg
usable frequency range	2000 Hz
temperature range	-40°C ÷ +160°C
interface	imperial armature
fixing points	n°8 on PCD ø 152,4 mm n°8 on PCD ø 304,8 mm

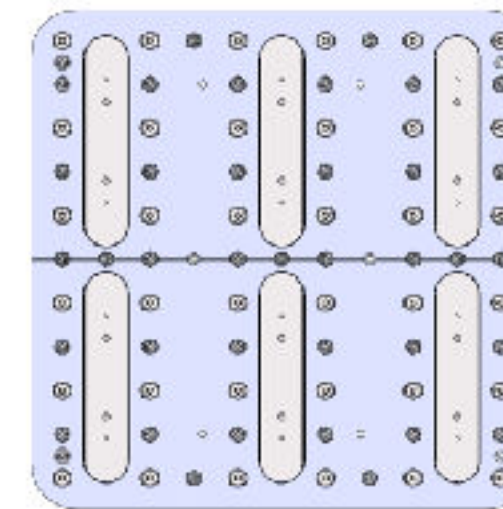

Instant Clamp 600SQ_100	
size	570 x 570 mm
weight	30 kg
usable frequency range	2000 Hz
temperature range	-40°C ÷ +160°C
interface	Standard RT 600 table
fixing points	n° 36 on grid 100 x 100 mm

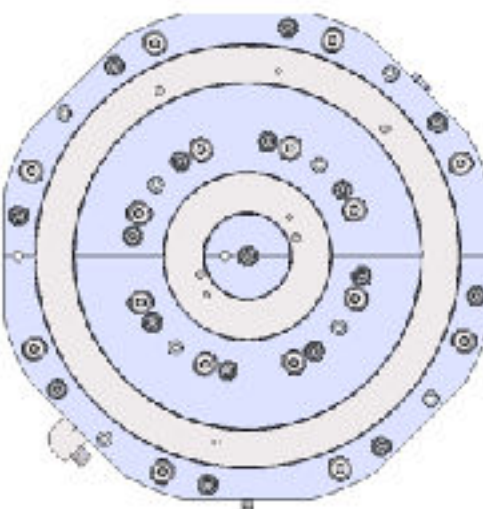

Instant Clamp 440 I	
size	ø 440 mm
weight	14,6 kg
usable frequency range	2000 Hz
temperature range	-40°C ÷ +160°C
interface	imperial armature
fixing points	n°8 on PCD ø 203,2 mm n°8 on PCD ø 406,4 mm

The **Instant Clamp** can be made with different sizes and hole pattern on specific request.

A GREAT INVESTMENT FOR YOUR LAB

With the economic savings on the fixtures design and the savings in operators time, the **Instant Clamp** pays for itself in a very short time.



The **Instant Clamp** can be ordered with standard dimensions for the armature of the most popular shakers or with customizable size and shape.

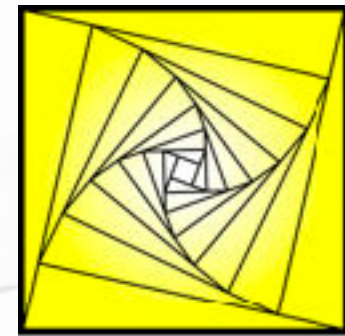

CENTROTECNICA
stress to ensure

To watch the video:

<https://www.youtube.com/watch?v=LopzzpISQtY>



For info or RFQs, pls contact us at mail: info@centrotecnica.it - phone: +39(0)255305888

Centrotecnica S.r.l. via Confalonieri, 23 - 20060 - Masate - MI - Italy www.centrotecnica.net